

ELECTRICAL MEASUREMENTS AND THEIR INDUSTRIAL APPLICATIONS

A REDESIGN OF THE VACUUM TUBE BRIDGE

<i>Also</i>	
IN THIS ISSUE	
	<i>Page</i>
IMPEDANCE BRIDGES ASSEMBLED FROM LABORATORY PARTS — PART V	5

● THE TYPE 561-A VACUUM TUBE BRIDGE* was introduced over nine years ago in order to provide a means of measuring the three dynamic tube coefficients — transconductance, amplification factor, and electrode resistance — over the wide ranges of values encountered under various operating conditions in the many new types of tubes then coming into use. The bridge embodied new measuring circuits to provide flexibility of operation and to permit the balancing of currents through the tube capacitances without affecting the measurement.

embodied new measuring circuits to provide flexibility of operation and to permit the balancing of currents through the tube capacitances without affecting the measurement.

*General Radio *Experimenter*, May, 1932.

FIGURE 1. Panel view of the bridge with its plug-in socket adapters.

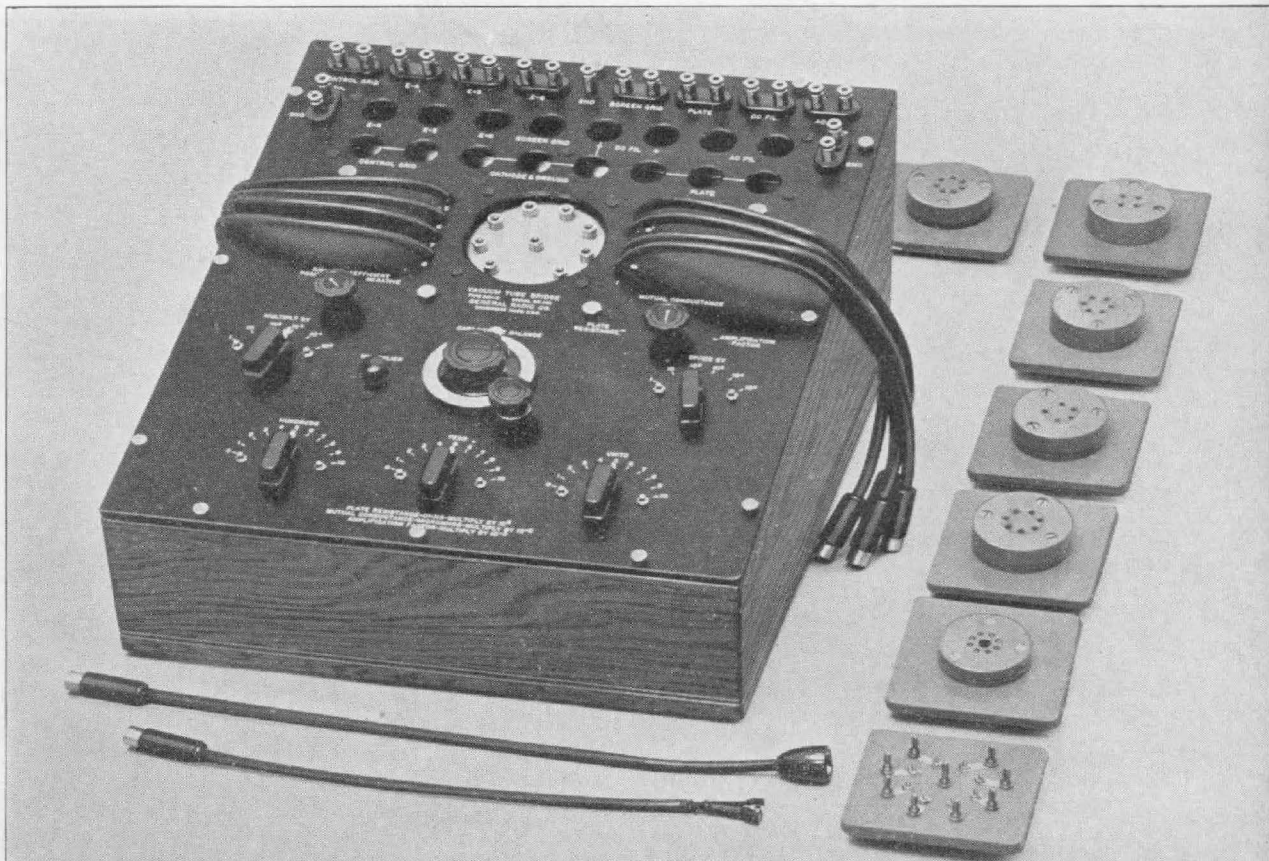

Although the original instrument has undergone only minor design modifications, it has been in steadily increasing demand ever since its introduction. The measuring circuits themselves have not been changed and have proved fully equal to the problems which have been encountered. The socket arrangement, however, has not proved adequate, although new adapters have been supplied as new requirements arose. Tube manufacturers and other users have usually found it desirable in setting up the bridge to employ their own socket arrangement and power-supply circuits instead of those supplied. A redesign of this portion of the bridge has been needed to provide a truly universal arrangement.

There is no evidence that the introduction of new base types is approaching an end, and the logical solution of the problem seems to be to eliminate the sockets entirely from the bridge and to

provide a jack plate, into which any desired socket can be inserted. Moreover, the tube industry has not found it possible to maintain standard base connections, and several different arrangements are now found even of cathode, heater, and shield connections. The decision was made, therefore, to provide a correspondingly numbered cord and plug for each socket terminal. By this means the desired electrodes can quickly be connected to the measuring circuits and power supplies, and several electrodes can readily be connected in parallel, as when testing a pentode connected as a triode.

Figure 1 is a photograph of the redesigned bridge, called TYPE 561-D, showing the jack plate with the TYPE 274 Jacks to receive the plugs on the socket plate. Figure 2 is an enlarged view of the tube-control portion with an octal socket inserted in position and the cords plugged in for measurements on a 6SK7 tube operated as a triode. It will be noted that three jacks, parallel connected, are

FIGURE 2. View of the tube control portion of the panel with cords plugged in for a typical measurement.

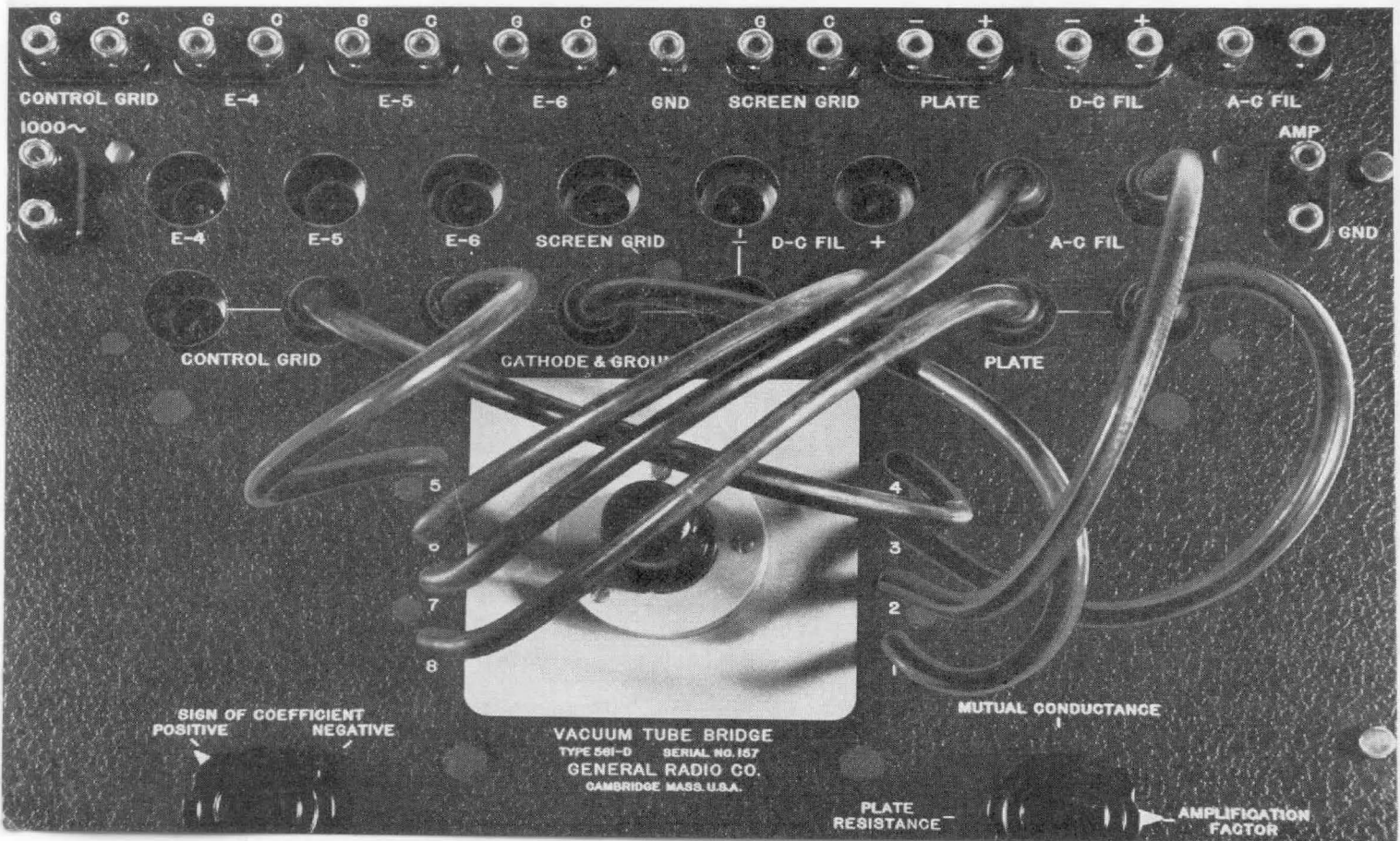

marked PLATE. These run to the plate portion of the measuring circuit and thence to the plate supply battery. In the example shown, the tube is operating as a triode, so cords from the suppressor, screen, and plate, bearing the numbers of the socket terminals 3, 6, and 8, respectively, are plugged into the three plate jacks. The cord from the control grid, number 4, is plugged into one of the two CONTROL GRID jacks, which lead through the grid portion of the measuring circuits to the grid bias source. The shell and cathode cords, numbered 1 and 5, are plugged into two of the CATHODE AND GROUND jacks and cords 2 and 7 into the A-C FIL jacks, thus completing the socket terminal connections. Leads to the required plate and control-grid voltage sources are not shown, but would be attached to the correspondingly marked pairs of binding posts at the top of the panel.

The general arrangement is very flexible and any imaginable electrode connections can be made quickly and easily. It will be noted that terminals for three extra voltage sources are provided, in addition to filament or heater, control grid, screen grid, and plate. This is so that measurements can be made with the suppressor and other auxiliary electrodes maintained at specified voltages other than cathode potential.

The cord and jack arrangement has the additional advantage of permitting full shielding of the various terminal connections, so that the stray capacitances which are balanced out in the measurement are only those of the tube and socket. The cords have a concentric braided shield, over which is molded rubber composition of high durability. Concentric plugs and jacks are used so that the shields run all the way to the jack plate, no matter what cross-connections are required. In the measuring

circuits a guard connection is employed, which is at plate potential, to shield the plate electrode and the wiring connected to it. This is brought to the outside terminals of the three plate jacks and thence through the shield braid on the cord to the socket terminals of the plate and other electrodes connected in parallel with it. When the shields of the other cords are plugged into any of the other jacks they are connected to ground. This double system of shielding, although involving complications in the design of the instrument, permits a very simple and straightforward technique on the part of the user, as no precautions need be taken in the measurement even when extreme values of the tube coefficients are encountered.

It is evident that any electrode or combination of electrodes can be connected to function as the control grid and any other electrode or combination as the plate or operating electrode. It is sometimes important, for example, to determine the dynamic resistance in the control grid circuit when the grid is taking current, and the parameters corresponding to amplification factor and transconductance can be measured showing the influence of the other elec-

FIGURE 3. Schematic diagram of the circuit for measuring transconductance.

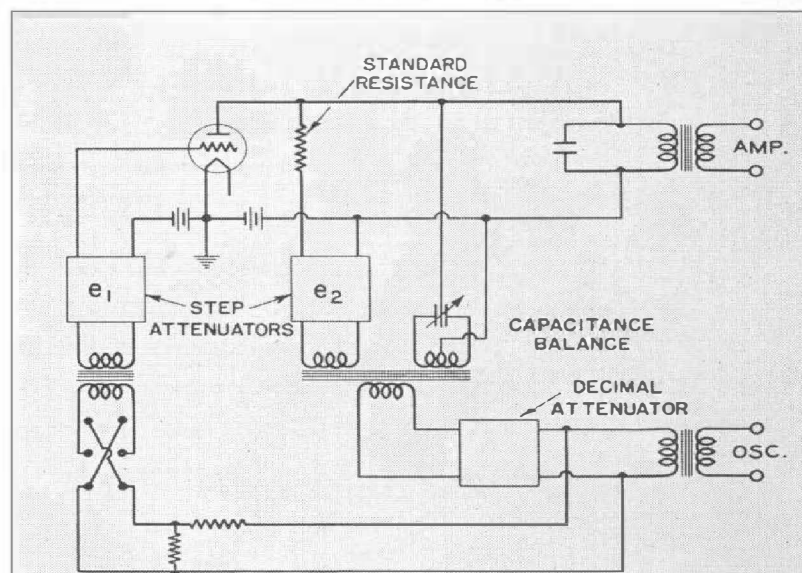

trodes on the grid current. Another quantity frequently of interest is the amplification factor of the screen electrode with respect to the plate current. The new cord and jack arrangement permits special measurements of this kind to be made as simply and directly as those of the usual quantities.

The three-tube coefficients are defined in terms of small incremental voltages or currents in the grid and plate circuits, and the bridge provides two independent 1000-cycle sources which can be varied over wide limits and inserted in any required circuit of the tube. Figure 3 shows the arrangement for transconductance measurements. The two separately-variable voltages for the grid and plate circuits are derived from the same 1000-cycle source. In order that the power supplies can be at ground potential and connected at one side directly to the cathode, the two voltages are obtained from the windings of separate transformers. On the secondary side of each transformer is a step attenuator for varying the voltage by factors of 10. In the primary of one of the transformers is a decimal attenuator giving to three significant figures the relative value of the plate-circuit voltage e_2 . The grid-circuit voltage e_1 causes an alternating current to flow through the output transformer in the plate circuit. The voltage e_2 , acting through the standard resistance R_s , sends a current in opposite phase, and balance is obtained when the two

currents through the output transformer cancel. The condition of balance is $e_1 S_m = e_2/R_s$ or $S_m = \frac{e_2^1}{e_1 R_s}$ and the transconductance is determined by the ratio of the two test voltages and the standard resistance. Any quadrature component through the output transformer, resulting from the tube interelectrode capacities, can be balanced out by the voltage of the extra split secondary, acting through the double-stator condenser. This adjustment does not affect the balance conditions for the in-phase components and consequently has no effect on the measurement.

A simple rearrangement of the two standard voltage sources permits the measurement of each of the other two coefficients, amplification factor, and plate resistance. In each case, the required quantity is expressed simply in terms of the ratio of the two test voltages, and can be read to three significant figures by the setting of the decimal attenuator. This is adjusted by the three controls at the bottom of the panel. A detailed analysis of the measuring circuits can be found in a paper[†] describing the original TYPE 561-A instrument.

— W. N. TUTTLE

General performance specifications for the TYPE 561-D Vacuum-Tube Bridge are identical with those for the older TYPE 561-C. The price remains unchanged at \$375.00.

[†]W. N. Tuttle, "Dynamic Measurement of Electron Tube Coefficients," Proc. I.R.E., No. 21, pp. 884-857, June, 1933.

CORRECTION

In the price list for TYPE 723 Vacuum-Tube Fork, appearing in the October issue of the *Experimenter*, there occurred a transposition of code words for the a-c power supply and the set of batteries. The correct code word for the TYPE 723-P1 A-C Power Supply is SNAKEYPACK, and that for the set of replacement batteries is SNAKEYBATT.

IMPEDANCE BRIDGES ASSEMBLED FROM LABORATORY PARTS

PART V—INDUCTANCE MEASUREMENTS

● THE MEASUREMENT of capacitance and dissipation factor of condensers by means of "bread board" bridges assembled from standard laboratory components has been discussed in previous *Experimenter* articles. Using similar techniques and equipment it is possible to make excellent measurements of inductance and reasonably good measurements of Q .¹

Inductance can be measured by comparison with a known inductance using a ratio arm,² or "simple impedance" bridge, or in terms of capacitance using a product arm² bridge. In the latter class are included the bridges of Hay, Owen, and Maxwell. These all measure inductance in terms of the product of two re-

sistances and a capacitance, but differ among themselves in the method of obtaining the resistance balance. In Figure 1 is shown a generalized bridge circuit suitable for the measurement of inductance, together with the complete equations of balance.

COMPONENTS REQUIRED

In setting up circuits to measure inductance, it would be desirable to utilize the same elements that were used for the capacitance bridges previously discussed. For the series-resistance bridge, the availability of three decade-resistance boxes, and a good mica standard condenser (0.01 μ f) as well as a TYPE 578-A Transformer and the necessary oscillator and detector was assumed. For the Schering circuit a TYPE 722 Precision Condenser and an inexpensive air condenser were required in addition. Circuits very similar to these two capacitance bridges, differing only in that one resistance arm and the capacitance arm are interchanged in po-

¹The symbol Q is used to denote the ratio of series resistance to series reactance. For an inductor, this is $\frac{\omega L}{R}$.

The term "storage factor" is also used for this quantity.

²The designations "ratio arm bridge" and "product arm bridge" mean simply that, for the former, the unknown reactance is determined by the ratio of two resistance arms, while for the latter the two resistance arms appear as a product in the balance equation. This terminology, although not generally accepted, has found limited use in the literature. See, for example, "Classification of Bridge Methods," J. G. Ferguson, B.S.T.J., Vol. XII, 1933, pp. 452-468; also, "A Brief Summary of Bridge Networks," W. T. Seeley, *Electrical Engineering*, March, 1940, pp. 108-113.

FIGURE 1. A generalized product arm bridge, showing complex impedances in all arms. The inductance in the P arm is measured in terms of the resistive product arms, A and B , and the capacitance standard C_N .

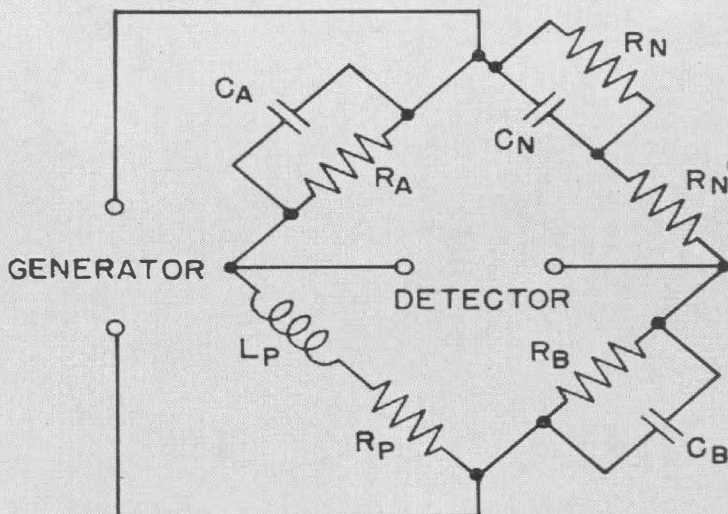

$$D_N = \frac{1}{Q_N} \cong R'_N \omega C_N + \frac{1}{R_N \omega C_N}$$

$$D'_N = R'_N \omega C_N$$

$$Q_A = R_A \omega C_A$$

$$Q_B = R_B \omega C_B$$

$$Q_P = \frac{\omega L_P}{R_P}$$

$$L_P = R_A R_B C_N \frac{1 - D_N Q_A - D_N Q_B - Q_A Q_B}{(1 + D_N'^2)(1 + Q_A^2)(1 + Q_B^2)}$$

$$Q_P = \frac{Q_N - Q_A - Q_B - Q_N Q_A Q_B}{1 - Q_A Q_B + Q_N Q_A + Q_N Q_B}$$

$$= \frac{1 - Q_A Q_B - D_N Q_A - D_N Q_B}{D_N + Q_A + Q_B - D_N Q_A Q_B}$$

sition, can be set up for inductance measurements, utilizing the same components.

THE HAY AND MAXWELL BRIDGES

A close analogue of the series-resistance type of capacitance bridge is the Hay bridge, shown in Figure 2a with simplified equations of balance.

The expression for the storage factor may be written in reciprocal form as

$$\frac{1}{Q_P} = D_P = \frac{R_P}{\omega L_P} = D_N + Q_A + Q_B + D_{N_0}$$

where D_{N_0} is the dissipation factor of the standard condenser itself, and D_N that added by the series resistor N .

In this form it is identical with the corresponding equation for the analogous capacitance bridge, *except* that all the residual factors *add*, whereas the Q 's of the ratio arms in a capacitance bridge are *subtractive*. This fact warns us immediately that, in general, less ac-

curacy can be expected in measuring Q than for the corresponding quantity for a condenser. It is also evident that the residuals cannot be neutralized by adjusting capacitance across resistive arms.

MAGNITUDE OF RESIDUALS

From our knowledge of the magnitude of the residuals we can readily estimate the order of magnitude of the error to be expected. Suppose we connect the bridge transformer in such a manner as to place the secondary shield-to-ground capacitance across the standard condenser (0.01 μ f), and set R_A and R_B to (say) 10,000 ohms. We may then use the values given in a previous article³ discussing the series-resistance capacitance bridge. These values were $Q_A = Q_B = 0.0008$, $D_{N_0} = 0.001$, which give approximately 0.0025 for the maximum value of $Q_A + Q_B + D_{N_0}$. This corresponds to an error of 25% in measuring a Q of 100, and to an error of 2% for $Q = 10$,

³General Radio *Experimenter*, July, 1941, p. 7.

FIGURE 2. Showing the Hay (a) and Maxwell (b) bridges. The two circuits differ only in the method of balancing the resistive component of the unknown. The Hay circuit utilizes resistance in *series* with the standard condenser, while in Maxwell's arrangement a parallel resistance is used. The approximate equations of balance are:

Hay : $L_P = \frac{R_A R_B C_N}{1 + D_N^2}$ $Q_P = \frac{1}{D_N + Q_A + Q_B}$ Maxwell : $L_P = R_A R_B C_N$ $Q_P = \frac{Q_N}{1 + Q_N(Q_A + Q_B)}$

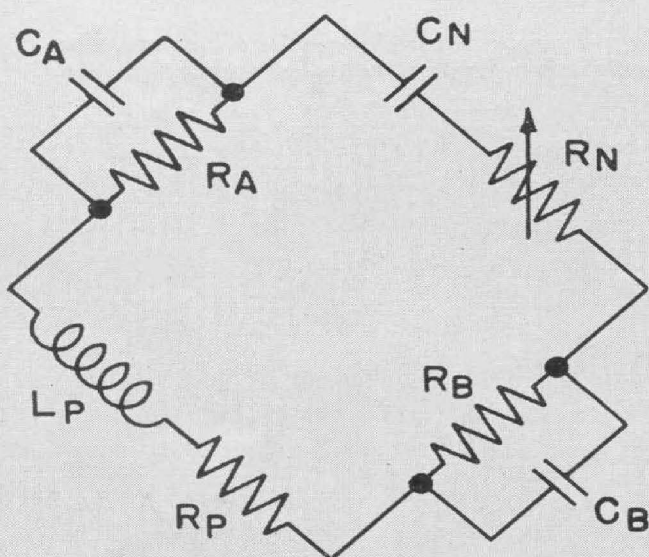

(a)

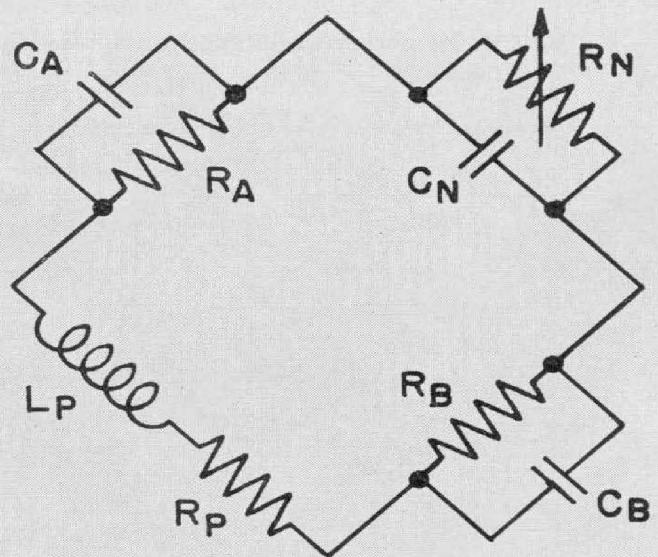

(b)

if the simple relation $Q = \frac{1}{D_N}$ is used.

This accuracy, at high values of Q , is rather poor but in many practical cases a knowledge of the approximate value of Q is sufficient, even when it is desired to know the inductance quite accurately. The error in the indicated value of Q can always be reduced somewhat, of course, by inserting the estimated values of the residual terms into the equations of balance.

The accuracy of inductance measurement with the Hay circuit will be limited largely by the accuracy with which the capacitance standard is known. With the standard known to $\pm 0.1\%$ an accuracy of approximately $\pm 0.3\%$ can be achieved. One inconvenient feature of the Hay bridge, however, is the factor

$$\frac{1}{1 + D_N^2}$$

in the equation for series inductance. For a coil whose Q is 30, this correction amounts to 0.1% , while at $Q = 10$ the correction is 1% . This correction cannot be ignored except at high values of Q , and for this reason Maxwell's arrangement is frequently preferred for coils of low Q .⁴ In this arrangement (Figure 2b) the coil resistance is balanced by a resistance in *parallel* with C_N , and no first order correction factor appears in the inductance equation. The difference in the inductance equation between these two bridges can be explained by saying that the product arm bridge measures series inductance in terms of the parallel capacitance of the opposite arm.⁵

A bench layout utilizing the Hay and Maxwell circuits is shown in Figure 3.

⁴In the TYPE 650-A Impedance Bridge, for instance, the Hay circuit is used for Q 's above 10, and the Maxwell circuit for Q 's below 10.

⁵Or conversely, measures *parallel* inductance in terms of *series* capacitance. This point will be discussed more fully in a subsequent installment.

The components required are the same as those used for the series-resistance type of capacitance bridge described in a previous article. The disposition of the transformer terminal capacitances is different, however. The small ($5 - 10 \mu\mu\text{f}$) capacitance is placed across a resistive arm, while the larger (approximately $100 \mu\mu\text{f}$) is placed across the unknown inductor of 0.1 henry or less is negligible. For higher inductances, a satisfactory correction may be made, assuming a value of $100 \mu\mu\text{f}$ for this capacitance.⁶

For this particular configuration the sum of the residual Q 's and D 's is approximately 0.002.

A 100,000-ohm resistance box across C_N ($= 0.01 \mu\text{f}$) will balance Q 's up to 6.3, while the same box may be placed in series with C_N for higher values of Q .

—IVAN G. EASTON

⁶The correction is 1% for $L = 2$ henries. An error of 10% in the assumed value of C_{SG} will, therefore, introduce an error of 0.1% in the computed value of L .

FIGURE 3. Connections for a bench layout of an inductance bridge. As shown, it is a Hay bridge, but can be converted to a Maxwell bridge by placing R_N in parallel with C_N .

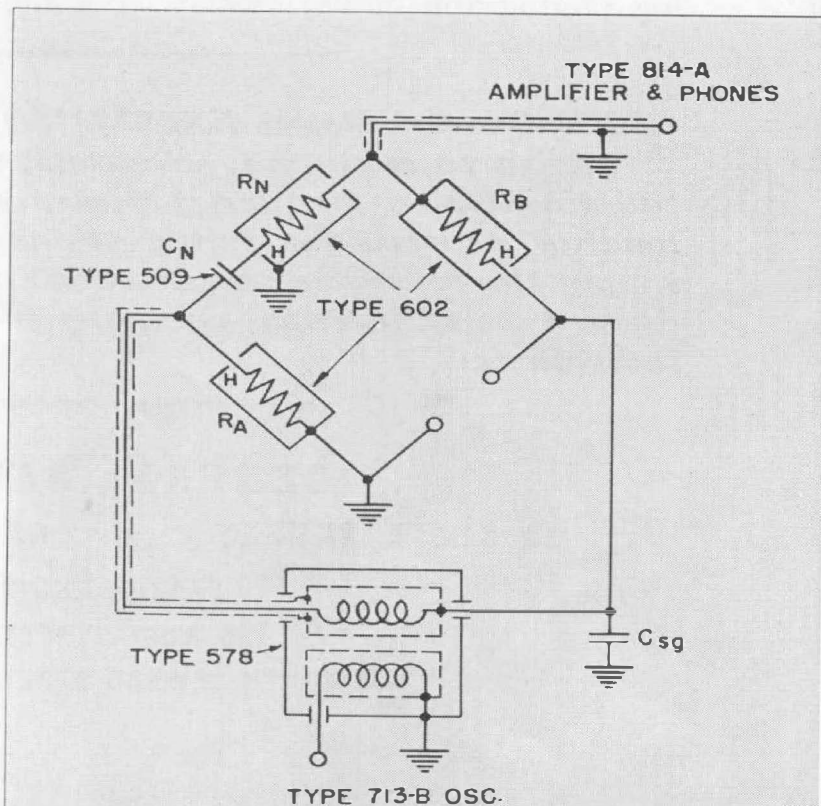

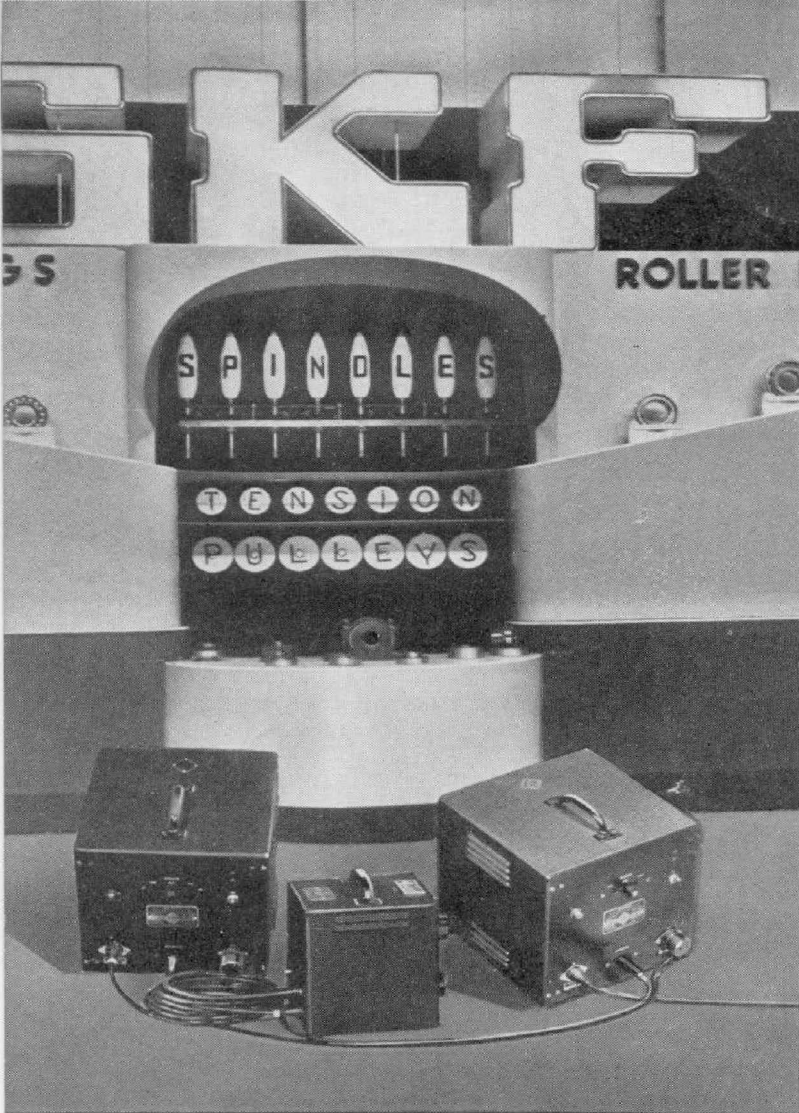

GETTING DISPLAY INTEREST WITH THE STROBOLUX

SKF Industries, Inc., at the Southern Textile Exhibit held last spring.

The eight spindles, each bearing a letter, were driven at a constant speed by a chain drive. The two rows of tension pulleys were driven similarly, but at a different speed from that of the spindles. Contactors on one spindle and one tension pulley provided a means of flashing the Strobotac. Controlled by the Strobotac were two Strobolux units, illuminating the spindles and tension pulleys.

A motor-driven switching system provided a repeating cycle of operation. First an ordinary incandescent lamp showed all parts rotating at high speed. Next the Stroboluxes, synchronized to the spindle speed, showed the spindles apparently stationary and spelling out the word SPINDLES. Finally the Stroboluxes were controlled by the speed of the tension pulleys, making the letters on them readable and those on the spindles illegible.

● AN INTERESTING APPLICATION of the Strobotac and Strobolux to advertising is shown in the accompanying photograph of the display used by

THE General Radio EXPERIMENTER is mailed without charge each month to engineers, scientists, technicians, and others interested in communication-frequency measurement and control problems. When sending requests for subscriptions and address-change notices, please supply the following information: name, company name, company address, type of business company is engaged in, and title or position of individual.

GENERAL RADIO COMPANY

30 STATE STREET - CAMBRIDGE A, MASSACHUSETTS

BRANCH ENGINEERING OFFICES

90 WEST STREET, NEW YORK CITY

1000 NORTH SEWARD STREET, LOS ANGELES, CALIFORNIA